



NPSA ADVICE NOTE

Vehicle Security Barrier Foundation Guidance

Purpose

This document highlights to security managers and specifiers the design terminology and considerations when installing Vehicle Security Barriers (VSBs), particularly regarding variations in site foundation design from the vehicle impact tested conditions. It highlights key factors when considering VSB foundations as described within vehicle impact test reports, PAS 68¹ and IWA 14-1², product supplier's data sheets and site installation drawings.

Foundation Installation Under Test Conditions

Under test conditions, manufacturers will test their VSB within a designed foundation arrangement. However, due to the temporary nature of the test installation and the costs involved the following can occur:

- The excavation may be limited in depth, so that the top of the foundation (concrete or steel plate) may not be level with the finished ground level (FGL), i.e. the product foundation does not include a finished surface to match the adjacent finished road conditions;
- The variation of finishes within the real world is not reflected within the test arrangement;
- The designed footing under test may not have considered environmental conditions that affect concrete or steel, therefore there may be inadequate reinforcement cover or corrosion protection layers may be missing;
- The testing scenario only involves a very localised area and therefore ground conditions preparation (e.g. blinding course below the footing) may not reflect real world conditions.

VSB Foundation Types

There are three distinct VSB foundation types noted within IWA 14-1², that are also referenced within the Catalogue of Impact Tested Vehicle Security Barriers (CITVSB)³:

- Deep Foundations – These foundations are greater than 0.5m below ground level
- Shallow Foundations – These foundations are less than or equal to 0.5m below ground level
- Surface Foundations – These foundations are usually fixed to the ground or freestanding with no requirement to excavate.

¹ BSI – PAS 68:2013 – Impact test specifications for vehicle security barrier systems

² ISO – IWA 14-1:2013 - Vehicle security barriers - Part 1: Performance requirement, vehicle impact test method and performance rating

³ NPSA – Catalogue of Impact Tested Vehicle Security Barriers (CITVSB)

The following terminology is commonly used on construction drawings:

- **FGL** – Finished Ground Level is the level of the ‘finished’ ground, i.e. top of asphalt road surface, paving slabs or blocks or landscaped grass etc
- **NGL** – Natural Ground Level refers to the level of ground before any excavation or filling has been carried out
- **SSL** – Structural Slab Level is top of the structural slab upon which vertical structures or ground finishes are placed
- **FFL** – Finished Floor Level refers to the uppermost surface of a floor once construction has been completed, but before any finishes have been applied. E.g. for concrete, the uppermost surface of a screeded finish. However, for some developments, e.g. residential, it can refer to the top of the finished surface, e.g. tiles, laminated floor or raised floor
- **AOD** – Above Ordnance Datum is a spot height above the vertical datum used for defining altitudes. In the UK the Ordnance Survey have defined ‘ODN’ as the Mean Sea Level (MSL) at Newlyn, Cornwall (in 1915-1921).
- **IL** – Invert Level is the lowest point of an excavation, typically used for lowest point water can flow on the inside of a drainage vessel.

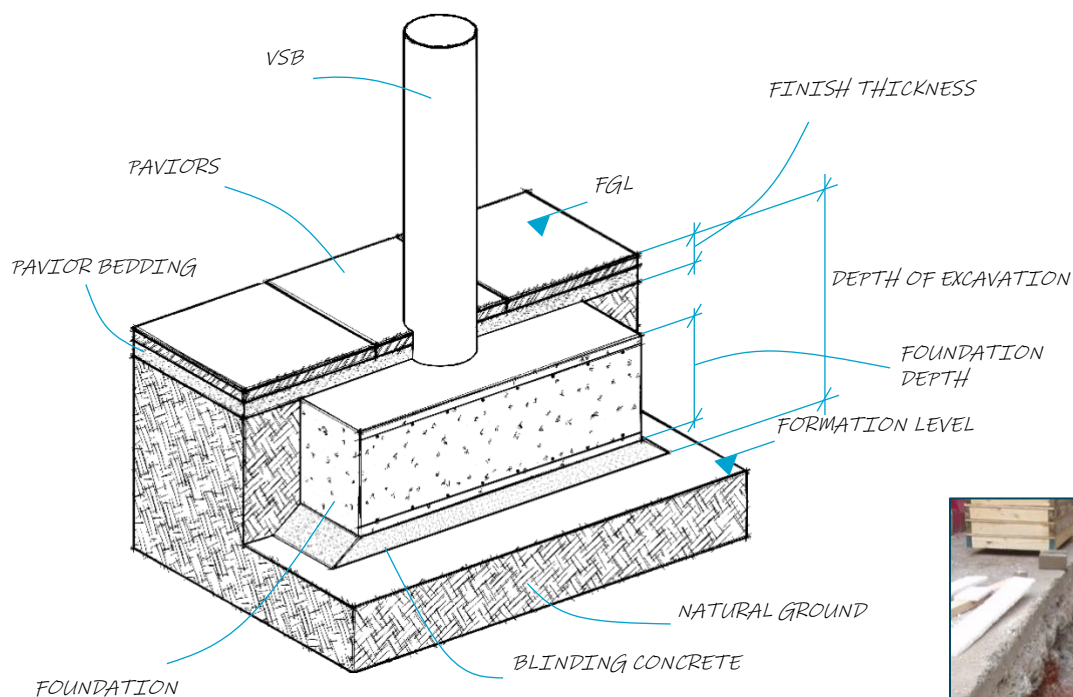

Figure 1: Deep Foundation (illustration and photograph)

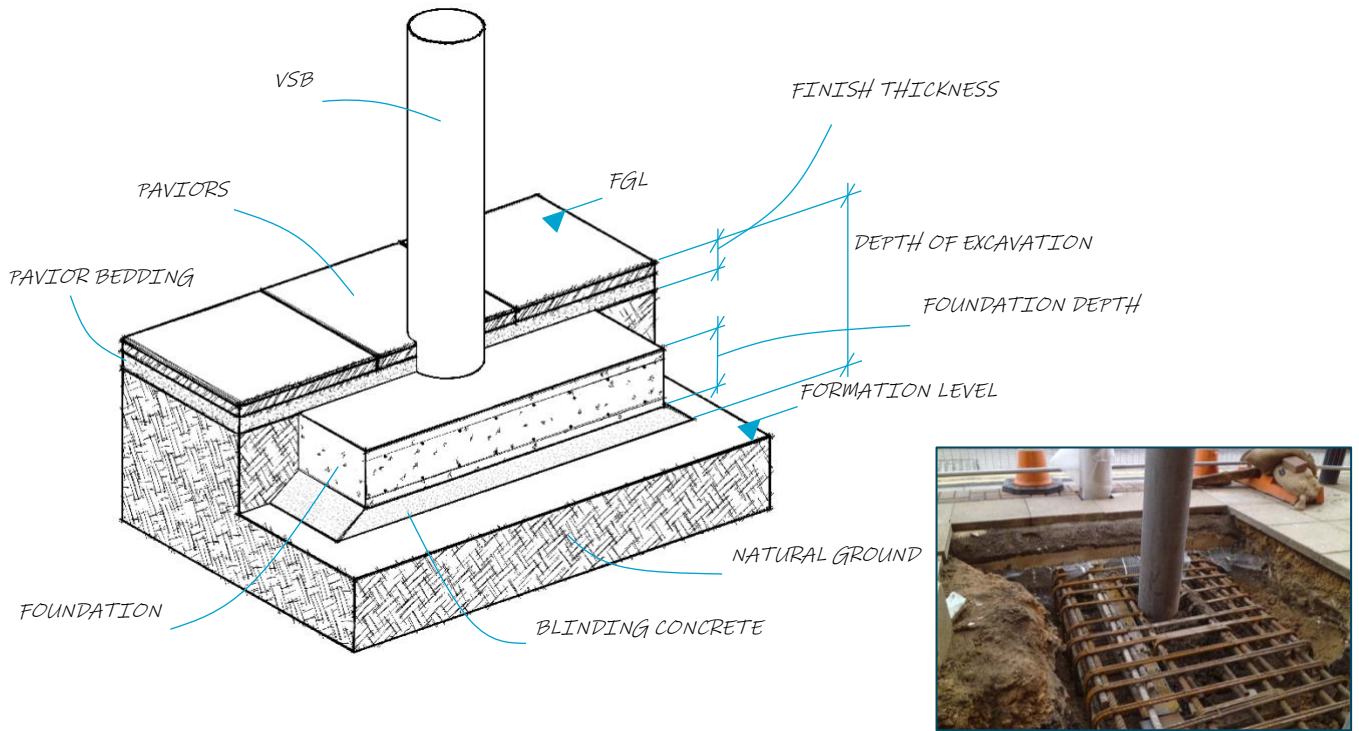

Figure 2: Shallow Foundation (illustration and photograph)

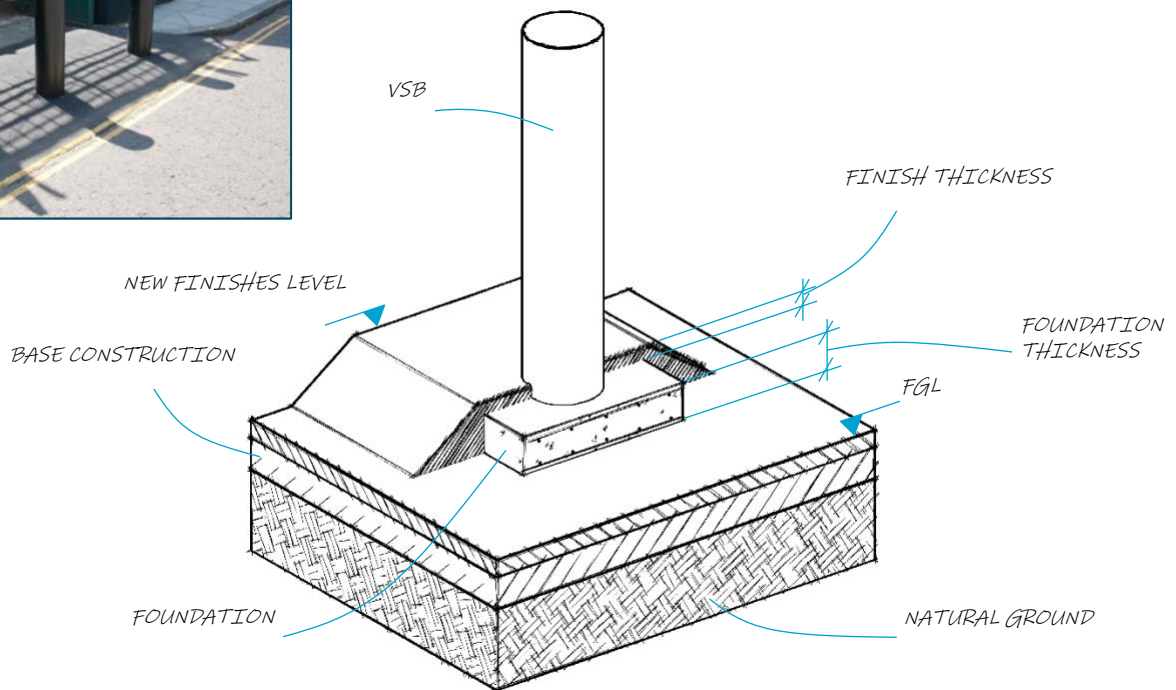

Figure 3: Surface Foundation (illustration and photograph)

Considerations for Installation

Project teams should familiarise themselves with NPSA's advice note on the selection and procurement of vehicle security barriers⁴.

The installation of VSBs and their foundations should match or exceed the conditions in which the barrier was tested, passed and rated to in accordance with PAS 68 and IWA 14-1. However, this is not always possible due to site conditions and constraints and hence, where a bespoke foundation is required, a suitably qualified and experienced engineer should be engaged to validate variations in design from the test conditions, such as a Principal engineer grade of the Register of Security Engineers and Specialists (RSES⁵) in Hostile Vehicle Mitigation (HVM) design. NPSA have produced guidance on procuring the services of security specialists⁶.

The following factors should be considered by specifiers to ensure compliance with PAS 69⁷ & IWA 14-2⁸:

- Below the concrete foundation, blinding will typically be required to level the sub-surface, the thickness of which may vary between 25 and 50mm;
- The depth of the surface finishes (paving slabs and bedding material) that need to be reinstated on top of the foundation. Typically, an allowance of 100mm should be made when evaluating the excavation depth;
- In lowering the foundation below the level of surface finishes to which it was tested, the performance of the VSB may be reduced;
- There may be a need to protect the steelwork of a VSB foundation from corrosion or underground obstructions with a membrane;
- Does the cover to the reinforcing steel need to be increased for environmental considerations?
This may require an additional 50mm or more to be added to the overall concrete thickness;
- Excavation and foundation depths (of designed footings) are not always the same and confusion should be avoided.

In allowing for the specified life span of the installation and the requirements for reinstatement of surface finishes, the excavation depth of a tested foundation may be 200mm more than the marketed depth, e.g. a designed foundation of 200mm may require an overall excavated depth of 400mm below FGL, thus increasing the overturning moment caused by the VSB if impacted.

Freedom of Information Act (FOIA)

This information is supplied in confidence and may not be disclosed other than to the agreed readership, without prior reference to NPSA. Within the UK, this material is exempt from disclosure under the relevant Freedom of Information Acts and may be subject to exemption under the Environmental Information Regulations and the Data Protection Act 1998.

Disclaimer

This document has been prepared by the National Protective Security Authority (NPSA). This document is provided on an information basis only, and whilst NPSA has used all reasonable

care in producing it, NPSA provides no warranty as to its accuracy or completeness. To the fullest extent permitted by law, NPSA accepts no liability whatsoever for any expense, liability, loss, damage, claim, or proceedings incurred or arising as a result of any error or omission in the document or arising from any person acting, refraining from acting, relying upon or otherwise using the document. You should make your own judgment with regard to the use of this document and seek independent professional advice on your particular circumstances.

© Crown Copyright 2020

⁴ NPSA – Advice Note: Due diligence in the selection and procurement of vehicle security barriers

⁵ ICE – Register of Security Engineers and Specialists, www.ice.org.uk/rses

⁶ NPSA – Procuring the Services of a Specialist Security Consultant When Undertaking a Project Relating to a Built Asset, Version 5, June 2019

⁷ BSI – PAS 69:2013 – Guidance for the selection, installation and use of vehicle security barriers

⁸ ISO – IWA 14-2:2013 – Vehicle Security Barriers – Part 2 Application